

Features

- JEDEC PC-133 SDRAM DIMM Compatible
- CAS 2 150MHz Modules (2:3:2) @ 150 MHz
 - CAS Latency = 2
 - RAS to CAS Delay = 3
 - Precharge Delay = 2
- Fast 4.5 ns Clock Access Time
- Overclock Existing PC Systems to 150 MHz +
- Ideal for Low Cost 150 MHz Bus Speed Systems
- Supports CAS Latency = 2, 3
- On-board Serial Presence Detect (SPD)
- Unbuffered 168-pin DIMM
- 4K Refresh / 64 ms
- Single 3.3V ± 0.3V Power Supply
- Available on-line at <http://www.pc133memory.com> or <http://www.mushkin.com>

Description

The Enhanced Memory Systems 64MB and 128MB CAS 2 150MHz HSDRAM DIMMs are the fastest unbuffered SDRAM DIMMs available. Low latency (2:3:2) at 150 MHz improves performance in high-end desktop publishing and graphics applications, particularly with UMA system architectures. The fast 4.5 ns clock access time allows unbuffered DIMM operation at 150 MHz for lower memory latency, and lower costs than registered DIMMs.

The 64MB module (SM6408DT-6.6) is organized as 8Mx64, and the 128MB module (SM12808DT-6.6) is organized as 16Mx64. The 128MB ECC module (SM12809DT-6.6) is organized as 16Mx72. Each module contains a serial presence EEPROM programmed by Enhanced Memory Systems, which contains information on the module type, module organization, component speed, and other attributes relevant to the system controller.

Pin	Symbol	Pin	Symbol	Pin	Symbol	Pin	Symbol
1	Vss	43	Vss	85	Vss	127	Vss
2	DQ0	44	DNU	86	DQ32	128	CKE0
3	DQ1	45	S2#	87	DQ33	129	S3#
4	DQ2	46	DQMB2	88	DQ34	130	DQMB6
5	DQ3	47	DQMB3	89	DQ35	131	DQMB7
6	Vdd	48	DNU	90	Vdd	132	RFU
7	DQ4	49	Vdd	91	DQ36	133	Vdd
8	DQ5	50	NC	92	DQ37	134	NC
9	DQ6	51	NC	93	DQ38	135	NC
10	DQ7	52	CB2	94	DQ39	136	CB6
11	DQ8	53	CB3	95	DQ40	137	CB7
12	Vss	54	Vss	96	Vss	138	Vss
13	DQ9	55	DQ16	97	DQ41	139	DQ48
14	DQ10	56	DQ17	98	DQ42	140	DQ49
15	DQ11	57	DQ18	99	DQ43	141	DQ50
16	DQ12	58	DQ19	100	DQ44	142	DQ51
17	DQ13	59	Vdd	101	DQ45	143	Vdd
18	Vdd	60	DQ20	102	Vdd	144	DQ52
19	DQ14	61	NC	103	DQ46	145	NC
20	DQ15	62	NC	104	DQ47	146	NC
21	CB0	63	CKE1	105	CB4	147	NC
22	CB1	64	Vss	106	CB5	148	Vss
23	Vss	65	DQ21	107	Vss	149	DQ53
24	NC	66	DQ22	108	NC	150	DQ54
25	NC	67	DQ23	109	NC	151	DQ55
26	Vdd	68	Vss	110	Vdd	152	Vss
27	WE#	69	DQ24	111	CAS#	153	DQ56
28	DQMB0	70	DQ25	112	DQMB4	154	DQ57
29	DQMB1	71	DQ26	113	DQMB5	155	DQ58
30	S0#	72	DQ27	114	S1#	156	DQ59
31	DNU	73	Vdd	115	RAS#	157	Vdd
32	Vss	74	DQ28	116	Vss	158	DQ60
33	A0	75	DQ29	117	A1	159	DQ61
34	A2	76	DQ30	118	A3	160	DQ62
35	A4	77	DQ31	119	A5	161	DQ63
36	A6	78	Vss	120	A7	162	Vss
37	A8	79	CK2	121	A9	163	CK3
38	A10/AP	80	NC	122	BA0	164	NC
39	BA1	81	WP	123	A11	165	SA0
40	Vdd	82	SDA	124	Vdd	166	SA1
41	Vdd	83	SCL	125	CK1	167	SA2
42	CK0	84	Vdd	126	RFU	168	Vdd

Pin Descriptions

Symbol	Type	Function
CK0,1,2,3	Input	Clocks: All SDRAM input signals are sampled on the positive edge of CK.
CKE0,1	Input	Clock Enables: CKE activate (high) or deactivate (low) the CK signals. Deactivating the clock initiates the Power-Down and Self-Refresh operations (all banks idle), or Clock Suspend operation. CKE is synchronous until the device enters Power-Down and Self-Refresh modes where it is asynchronous until the mode is exited.
S0,1,2,3#	Input	Chip Select: S# enables (low) or disables (high) the command decoder. When the command decoder is disabled, new commands are ignored but previous operations continue.
RAS#, CAS#, WE#	Input	Command Inputs: Sampled on the rising edge of CK, these inputs define the command to be executed.
BA1, BA0	Input	Bank Addresses: These inputs define to which of the 4 banks a given command is being applied.
A0-A11	Input	Address Inputs: A0-A11 define the row address during the Bank Activate command. A0-A8 define the column address during Read and Write commands. A10/AP invokes the Auto-precharge operation. During manual Precharge commands, A10/AP low specifies a single bank precharge while A10/AP high precharges all banks. The address inputs are also used to program the Mode Register.
DQ0-DQ63	Input/Output	Data I/O: Data bus inputs and outputs. For Write cycles, input data is applied to these pins and must be set-up and held relative to the rising edge of clock. For Read cycles, the device drives output data on these pins after the CAS latency is satisfied.
DQMB0-7	Input	Data I/O Mask Inputs: DQMB0-7 inputs mask write data (zero latency) and acts as a synchronous output enable (2-cycle latency) for read data.
CB0-7	Input/Output	ECC Check Bits
V _{DD}	Supply	Power Supply: +3.3 V
V _{SS}	Supply	Ground
SDA	Input/Output	Serial Presence-Detect Data: SDA is a bi-directional pin used to transfer addresses and data into and data out of the presence-detect portion of the module.
SCL	Input	Serial Clock for Presence-Detect: SCL is used to synchronize the presence detect data transfer to and from the module
SA0-2	Input	Presence-Detect Address Inputs: These pins are used to configure the presence detect device.
WP	Input	Serial Presence Detect Write Protect: Active high inhibits writes to the SPD EEPROM. WP must be driven low for normal read/write operations.
RFU	-	Reserved for Future Use: These pins should be left unconnected.
DNU	-	Do not use.
NC	-	No connect - open pin.

64MB DIMM Functional Block Diagram – SM6408DT-6.6

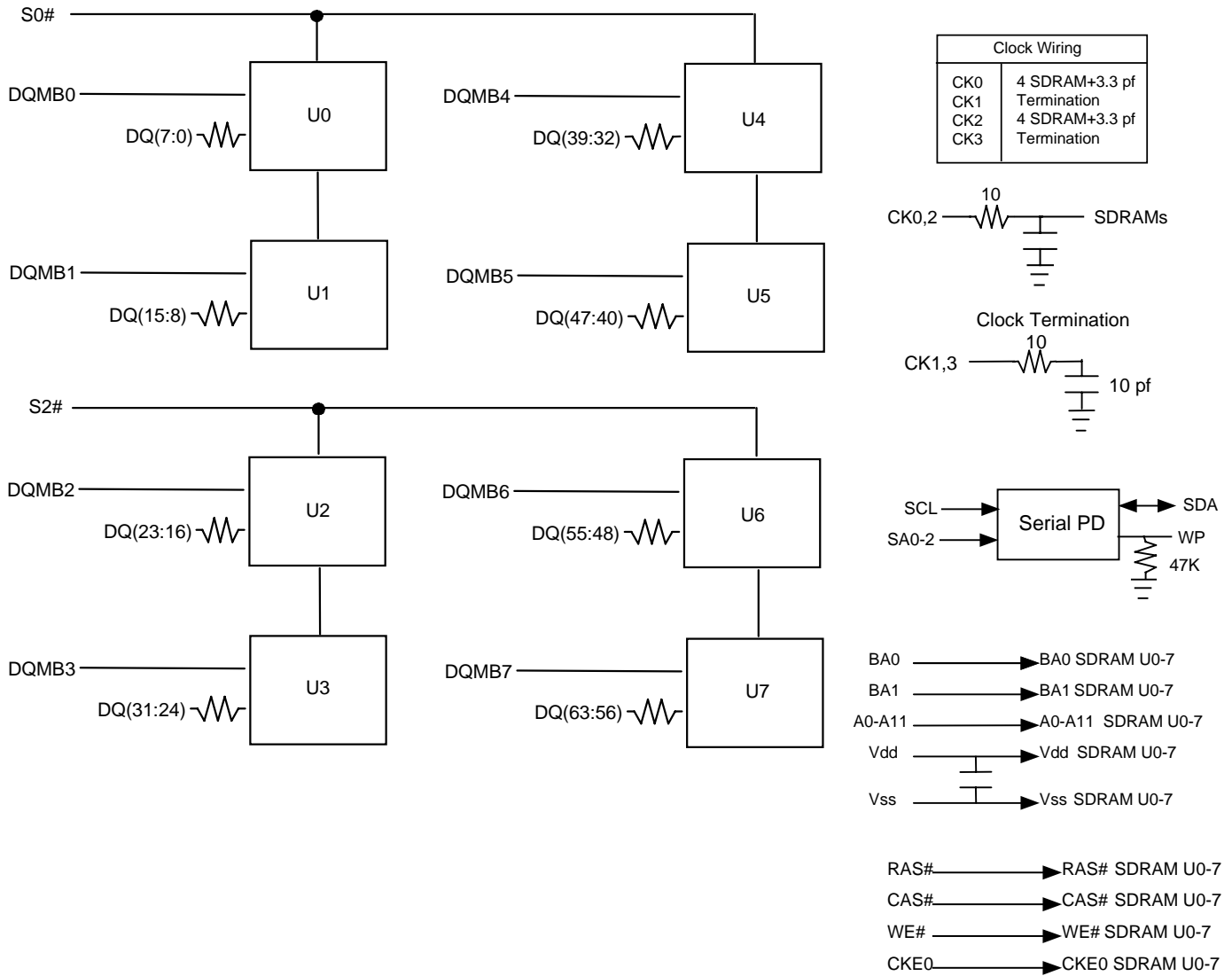

Note: All DQ resistor values are 10 ohms
 All CK resistor values are 10 ohms
 U0-U7 are SM3603T-6.6

128MB DIMM Functional Block Diagram – SM12808DT-6.6

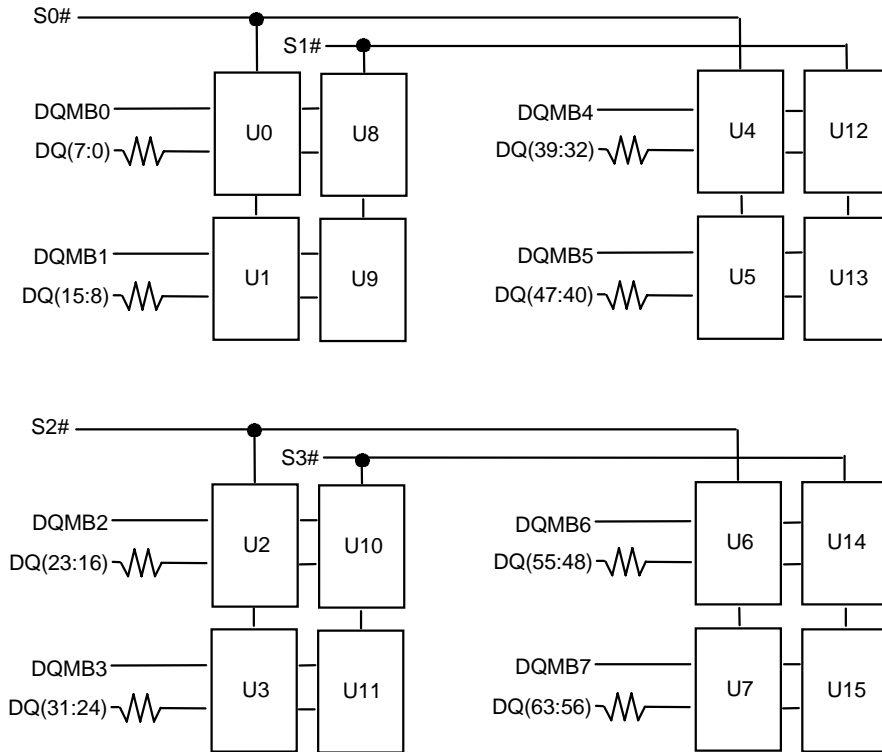

Clock Wiring	
CK0	4 SDRAM+3.3 pf
CK1	4 SDRAM+3.3 pf
CK2	4 SDRAM+3.3 pf
CK3	4 SDRAM+3.3 pf

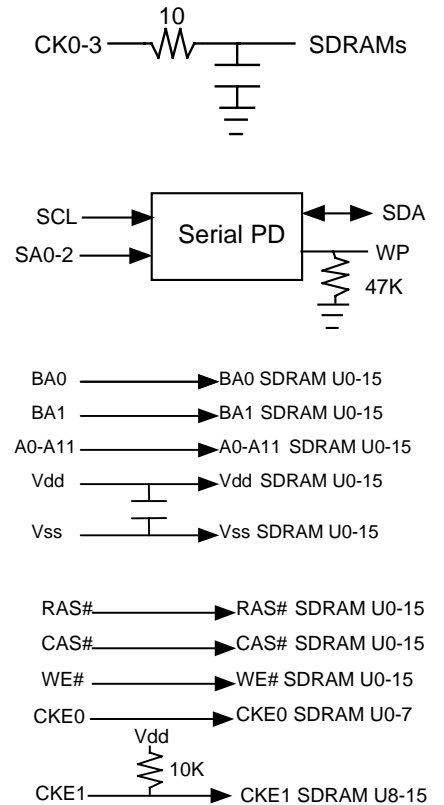

Note: All DQ resistor values are 10 ohms
All CK resistor values are 10 ohms
U0-U15 are SM3603T-6.6

128MB ECC DIMM Functional Block Diagram – SM12809DT-6.6

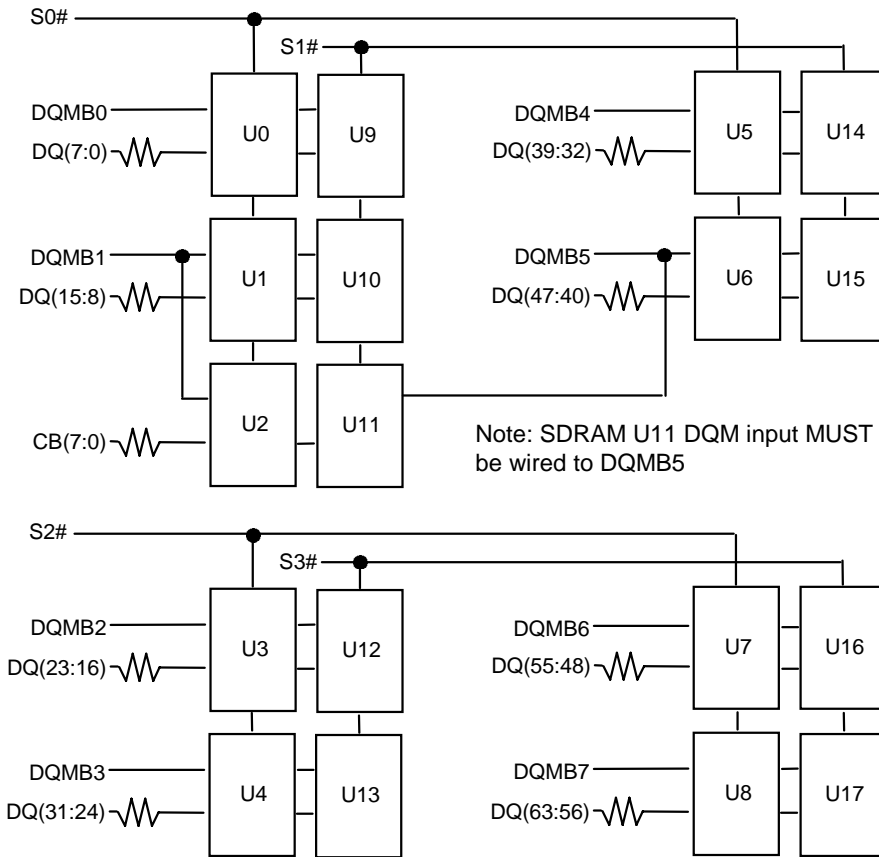

Clock Wiring	
CK0	5 SDRAM
CK1	5 SDRAM
CK2	4 SDRAM+3.3 pf
CK3	4 SDRAM+3.3 pf

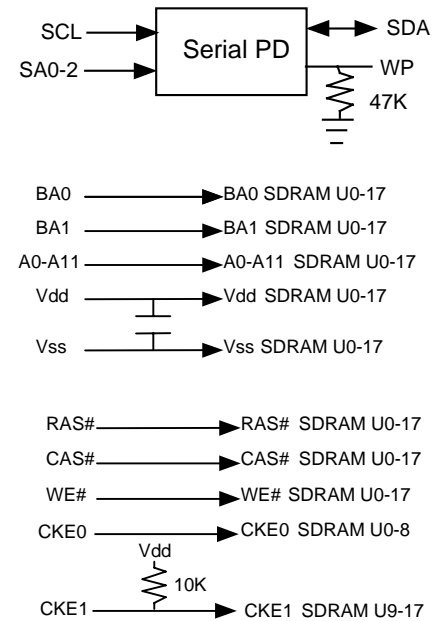
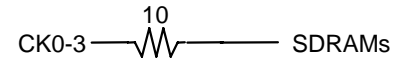

Note: All DQ resistor values are 10 ohms
All CK resistor values are 10 ohms
U0-U15 are SM3603T-6.6

Electrical Characteristics

Absolute Maximum Ratings

Description	Symbol	Value
Power Supply Voltage	V_{DD}	-1V to +4.6V
Voltage on any Pin with Respect to Ground	V_{IN}, V_{OUT}	-0.5V to +4.6V
Operating Temperature (ambient)	T_A	0°C to +70°C
Storage Temperature	T_{stg}	-55°C to +125°C
Power Dissipation	P_D	TBD
DC Output Current (I/O pins)	I_{OUT}	50mA

Stresses greater than those listed under Absolute Maximum Ratings may cause permanent damage to the device. This is a stress rating only, and the functional operation of the device at these, or any other conditions above those listed in the operational section of the specification, is not implied. Exposure to conditions at absolute maximum ratings for extended periods may affect device reliability.

DC Operating Conditions ($T_A = 0^\circ\text{C}$ to 70°C)

Symbol	Parameter	Min	Typical	Max	Units	Notes
V_{DD}	Supply Voltage	3.0	3.3	3.6	V	
V_{IH}	Input High Voltage	2.0	3.3	$V_{DD} + 0.3$	V	
V_{IL}	Input Low Voltage	-0.3	0.0	0.8	V	
$I_{I(L)}$	Input Leakage Current	-	-	± 1	μA	
$I_{O(L)}$	Output Leakage Current	-	-	± 1	μA	
V_{OH}	Output High Voltage ($I_{OUT} = -4\text{mA}$)	2.4	-	V_{DD}	V	
V_{OL}	Output Low Voltage ($I_{OUT} = +4\text{mA}$)	0.0	-	0.4	V	

Capacitance ($T_A = 25^\circ\text{C}$, $f = 1\text{MHz}$, $V_{DD} = 3.3\text{V} \pm 0.3\text{V}$, not 100% tested)

Symbol	Parameter	64MB	128MB		Units
		non-ECC	non-ECC	ECC	
C_{In1}	Input Capacitance (BA1, BA0, A0-11, RAS, CAS)	38	65	71	pF
C_{In2}	Input Capacitance (S0 - S3)	21	21	24	pF
C_{In3}	Input Capacitance (CK0 - CK3)	26	26	26	pF
C_{In4}	Input Capacitance (CKE0, CKE1)	38	38	42	pF
C_{In5}	Input Capacitance (DQMB0-7)	12	14	14	pF
C_{In6}	Input Capacitance (SCL, SA0-2)	12	12	12	pF
$C_{I/O1}$	I/O Capacitance (SDA)	12	12	12	pF
$C_{I/O2}$	I/O Capacitance (DQ0-63, CB0-7)	8.5	13	13	pF

AC Characteristics ($T_A = 0^\circ\text{C}$ to 70°C)

1. An initial pause of 200 μs is required after power-up, then a Precharge All Banks command must be given followed by a minimum of eight Auto (CBR) Refresh cycles before the Mode Register Set operation can begin.
2. AC timing tests have $V_{IL} = 0.8\text{V}$ and $V_{IH} = 2.0\text{V}$ with the timing referenced to the $V_{TT} = 1.4\text{V}$ crossover point.

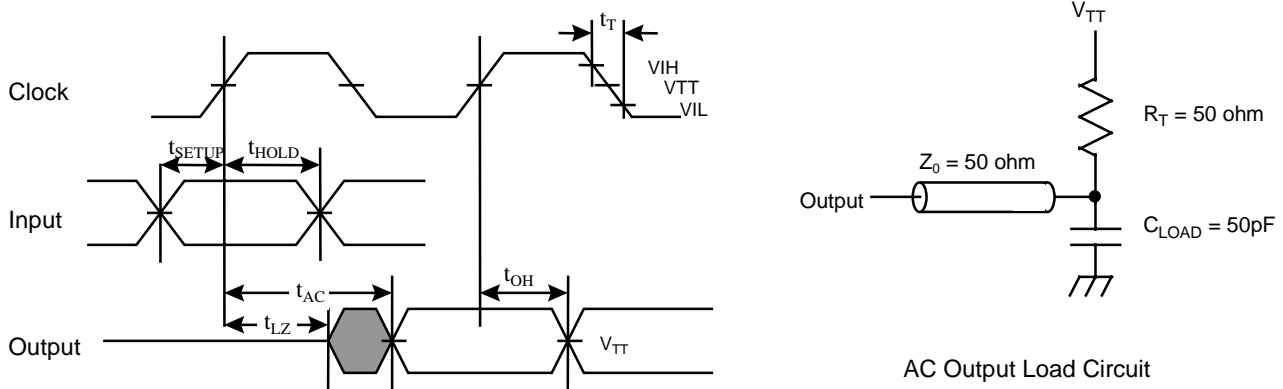

3. The transition time is measured between V_{IH} and V_{IL} (or between V_{IH} and V_{IL}).
4. AC measurements assume $t_{\text{T}} = 1\text{ns}$.
5. In addition to meeting the transition rate specification, the clock and CKE must transition V_{IH} and V_{IL} (or between V_{IH} and V_{IL}) in a monotonic manner.

AC Operating Conditions ($T_A = 0^\circ\text{C}$ to 70°C)

Clock and Clock Enable Parameters

Symbol	Parameter	-6.6		Units	Notes
		Min	Max		
t_{CK3}	Clock Cycle Time, CL = 3	6.6		ns	
t_{CK2}	Clock Cycle Time, CL = 2	6.6		ns	
t_{CKH3}, t_{CKL3}	Clock High & Low Times, CL=3	2.5	-	ns	1
t_{CKH2}, t_{CKL2}	Clock High & Low Times, CL=2	2.5	-	ns	1
t_{CKES}	Clock Enable Set-Up Time	1.5	-	ns	
t_{CKEH}	Clock Enable Hold Time	0.8	-	ns	
t_{CKSP}	CKE Set-Up Time (Power down mode)	1.5	-	ns	
t_T	Transition Time (Rise and Fall)	-	4	ns	

Notes:

- Assumes clock rise and fall times are equal to 1ns. If rise or fall time exceeds 1ns, other AC timing parameters must be compensated by an additional $[(t_{rise}+t_{fall})/2-1]$ ns.

Common Parameters

Symbol	Parameter	-6.6		Units	Notes
		Min	Max		
t_{CS}	Command and Address Set-Up Time	1.5	-	ns	
t_{CH}	Command and Address Hold Time	0.8	-	ns	
t_{RCD}	RAS to CAS Delay Time	18.0	-	ns	
t_{RC}	Bank Cycle Time	53.3	120K	ns	
t_{RAS}	Bank Active Time	33.3	120K	ns	
t_{RP}	Precharge Time	13.3	-	ns	
t_{RRD}	Bank to Bank Delay Time (Alt. Bank)	13.3	-	ns	
t_{CCD}	CAS to CAS Delay Time (Same Bank)	6.6	-	ns	
t_{MRD}	Mode Register Set to Active Delay	2	-	CLK	

Read and Write Parameters

Symbol	Parameter	-6.6		Units	Notes
		Min	Max		
t _{AC3}	Clock Access Time, CL = 3	-	4.5	ns	1,2
t _{AC2}	Clock Access Time, CL = 2	-	4.5	ns	1,2
t _{OH3}	Data Output Hold Time (CL=3)	2.7	-	ns	
t _{OH2}	Data Output Hold Time (CL=2)	2.7	-	ns	
t _{LZ}	Data Output to Low-Z Time	1	-	ns	
t _{HZ2}	Data Output to High-Z Time (CL=2, 3)	-	4.5	ns	3
t _{DS}	Data Input Set-Up Time	1.5	-	ns	
t _{DH}	Data Input Hold Time	0.8	-	ns	
t _{DPL}	Data Input to Precharge	13.3	-	ns	
t _{DAL}	Data Input to ACTV/Refresh	4	-	CLK	4
t _{DQW}	Data Write Mask Latency	0	-	CLK	
t _{DQZ}	DQM Data Output Disable Time	2	-	CLK	

Notes:

1. Access time is measured at 1.4V (LVTTTL) at max clock rate for the CAS latency specified. See AC Test Load.
2. Access time is based on a clock rise time of 1ns. If clock rise time is longer than 1ns, then (trise/2-0.5) ns must be added to the access time.
3. Referenced to the time at which the output achieves an open circuit condition.
4. t_{DAL} is equal to t_{DPL} + t_{RP} and can be less than 4 clocks if t_{DPL} and t_{RP} are both satisfied.

Refresh Parameters

Symbol	Parameter	-6.6		Units	Notes
		Min	Max		
t _{REF}	Refresh Period	-	64	ms	1, 2
t _{SREX}	Self Refresh Exit Time	2CLK+t _{RC}	-	ns	3
t _{RFC}	Refresh Cycle Time	60.0		ns	

Notes:

1. 4096 cycles.
2. Any time that the refresh period has been exceeded, a minimum of two Auto-Refresh (CBR) commands must be given to “wake up” the device.
3. Self-Refresh exit is a synchronous operation and begins on the 2nd positive clock edge after CKE returns high. Self-Refresh Exit is not completed until t_{RC} is satisfied once the Self-Refresh Exit command is registered.

Serial Presence Detect (SPD) for PC-150 DIMMs

Byte	Description	64MB		128MB		64MB		128MB		
		8Mx8 (8 pcs)		2 x 8Mx8 (16 pcs)		8Mx8 (8)		2 x 8Mx8 (8)		
** HEX CODE **										
0	Number of bytes written into EEPROM	128		128		80	80			
1	Total number of SPD bytes	256		256		08	08			
2	Memory Type	SDRAM		SDRAM		04	04			
3	Number of Row Addresses	12		12		0C	0C			
4	Number of Column Addresses	9		9		09	09			
5	Number of Module Banks	1		2		01	02			
6	Module Data Width	x64	x64	x64		40	40			
		x72		x72			48			
7	Module Data Width (cont'd)	0		0		00	00			
8	Voltage Interface Levels	LVTTL		LVTTL		01	01			
9	Cycle Time at max CAS Latency	6.6 ns		6.6 ns		66	66			
10	SDRAM Clock Access Time (CL=3)	4.5 ns		4.5 ns		45	45			
11	DIMM config (non-parity, parity, ECC)	x64	--- Non-parity ---			00	00			
		x72	--- ECC ---				02			
12	Refresh Rate and Type	--- 15.625us / Self ---				80	80			
13	Primary SDRAM Width	x8		x8		08	08			
14	Error Checking Data Width	x64	N/A		N/A		00	00		
		x72			x8			08		
15	Min. CAS-to-CAS Delay (tCCD)	1 clk		1 clk		01	01			
16	Burst Lengths Supported	--- 1,2,4,8,Full Pg ---				8F	8F			
17	Number of Banks on SDRAM Device	4		4		04	04			
18	CAS Latencies Supported	2,3		2,3		06	06			
19	CS Latency	0		0		01	01			
20	Write Latency	0		0		01	01			
21	SDRAM Module Attributes	--- Unbuffered ---				00	00			
22	SDRAM Device Attributes	+/-10% Vdd, Precharge All, Wr-1/RdBst				0E	0E			
23	Min. Clock Cycle Time at CL=2	6.6 ns		6.6 ns		66	66			
24	Clock Access Time at CL=2 (tAC2)	4.5 ns		4.5 ns		45	45			
25	Min. Clock Cycle Time at CL=1	N/A		N/A		00	00			
26	Clock Access Time at CL=1 (tAC1)	N/A		N/A		00	00			
27	Min. Row Precharge Time (tRP)	13.3 ns		13.3 ns		0E	0E			
28	Min. Row-to-Row Delay (tRRD)	13.3 ns		13.3 ns		0E	0E			
29	Min. RAS-to-CAS Delay (tRCD)	18 ns		18 ns		12	12			
30	Min. RAS Pulse Width (tRAS)	33.3 ns		33.3 ns		22	22			
31	Density of each bank on module	64MB		64MB		10	10			
32	Cmd/Addr input set-up time	1.5 ns		1.5 ns		15	15			
33	Cmd/Addr input hold time	0.8 ns		0.8 ns		08	08			
34	Data input set-up time	1.5 ns		1.5 ns		15	15			
35	Data input hold time	0.8 ns		0.8 ns		08	08			
36-61	Superset Information	-				00	00			
62	SPD Rev.	1.2				12	12			
63	Checksum for bytes 0-62	x64				17	18			
		x72					2A			
64-71	JEDEC ID code	Enhanced Memory Systems				7F32FFFFFFFFFFFF				
72	Manufacturing Location					xxxx	xxxx			
73-90	Manufacturer's Part #	SM6408DT		SM12808DT		xxxx	xxxx			
91,92	PCB Rev. Code					rrrr	rrrr			
93,94	Manufacturing Date	yyww code				yyww	yyww			
95-98	Assembly Serial #	serial number				ssss	ssss			
99-125	Manufacturer's Specific Data	open				00	00			
126	Intel specification frequency	133MHz				85	85			
127	Intel specification CL and clock support					A5	F5			
128-255	Open for Customer Use					00	00			

Revision Log

Revision	Date	Summary of Changes
1.0	7/27/00	First release.

**CAS2/150MHz HSDRAM
64MB, 128MB DIMM**

Ordering Information

These CAS2/150MHz HSDRAM DIMMs may be purchased on-line at <http://www.pc133memory.com>, or <http://www.mushkin.com>, which are e-commerce functions of Enhanced Memory Systems Inc., or call 1-800-569-1868.

Part Number	Capacity	I/O Width	I/O Type	Package	Power Supply	Maximum Operating Frequency (MHz)
SM6408DT-6.6	64 MB	x64	LVTTL	168-pin DIMM	3.3V	150
SM12808DT-6.6	128 MB	x64	LVTTL	168-pin DIMM	3.3V	150
SM12809DT-6.6	128 MB	x72	LVTTL	168-pin DIMM	3.3V	150

Note: Enhanced Memory Systems Low Latency PC-150 HSDRAM DIMMs are labeled per the Intel PC SDRAM DIMM Naming Convention. This convention requires identification of the bus speed, latency, clock access time, and SPD revision code. The code for these DIMM modules is PC150-232-45120.